

FLOOR PLAN

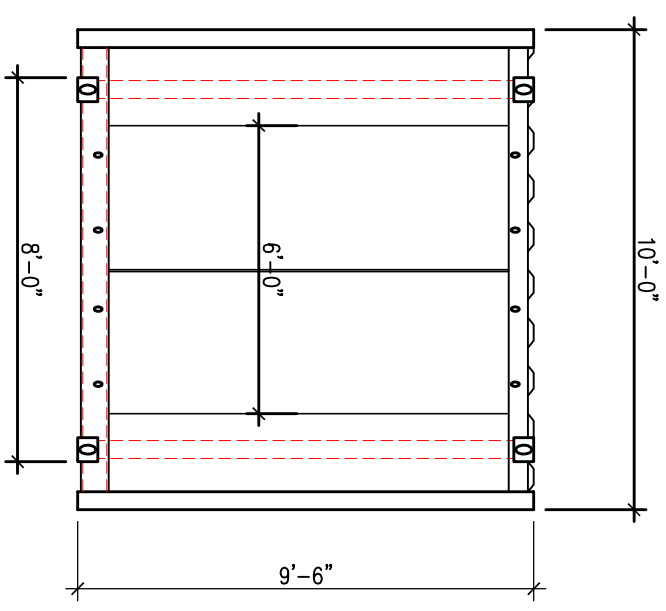

END VIEW

REV./DATE	DESCRIPTION

NOTE: This drawing, as an instrument of service, is the property of SHELTER INDUSTRIES, INC. and may not be used or reproduced without prior written consent of this office.



TITLE  
10' X 40' FIELD OFFICE - PLAN

SCALE  
1/4" = 1'-0"  
DRAWN  
ROB M.

DATE  
Jan. 15, 2008  
PROJECT No.  
P08-????

SHT. No.  
A1